

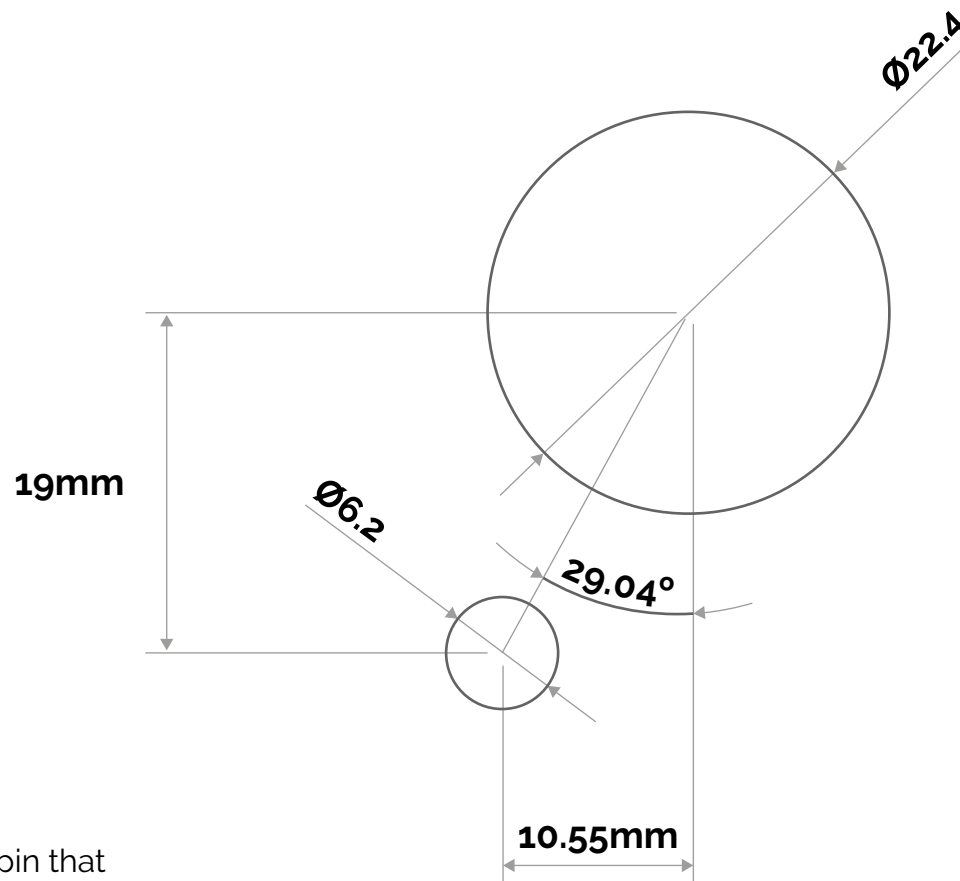

Undersea Centre Ltd
SERVING THE DIVING INDUSTRY SINCE 1974

Unit 3, The Crosshouse Centre,
Crosshouse Road,
Southampton SO14 5GZ
T: 02382 358 111
E: info@undersea-centre.com
W: undersea-centre.com



The 6mm hole for the locating pin that prevents the valve moving, should be a blind hole 6mm deep. We use an 8mm thick panel.

But if you are using thinner material, we suggest you use some Loctite in the pin recess to retain the pin.

Drawn October 2016
For illustration purposes only, drawings are not to scale.

Drilling Template	
Part number	Description
7501 and 7506	Drilling template for 7501 and 7506 valves